

ETA 4 1450 r.p.m

نوع پمپ	قدرت		جریان A	قطر بروانه D (mm)	قطر فلانچ پمپ (mm)		آبدهی (m ³ /h)	40	50	60	65	70	75	80	85	90	95	100	110	120	130
	KW	HP			رانس	مکش		35	40	45	50.5	57.5	32.5	31.5	30.5	29	27.4	25.5	23.5	20.7	18
ETA4 80-400 E	15	20	29	320	80	100	H (m)	35	33.7	32.5	31.5	30.5	29	27.4	25.5	23.5	20.7	18	*	*	*
ETA4 80-400 D	18.5	25	38	340	80	100		40	39	38.2	37.5	36.5	35.2	34	32.5	31	28.9	26.4	20	*	*
ETA4 80-400 C	22	30	43.5	360	80	100		45	44.5	44	43.7	43.2	42.5	41.5	40.2	38.7	37	35	29.5	*	*
ETA4 80-400 B	30	41	58	380	80	100		50.5	50.2	50	49.5	49.1	48.3	47.5	46.5	45.5	44	42.3	37.8	31	*
ETA4 80-400 A	30	41	58	404	80	100		57.5	57.2	57	56.7	56.5	56	55.5	54.7	54	52.9	51.5	47.6	43	37

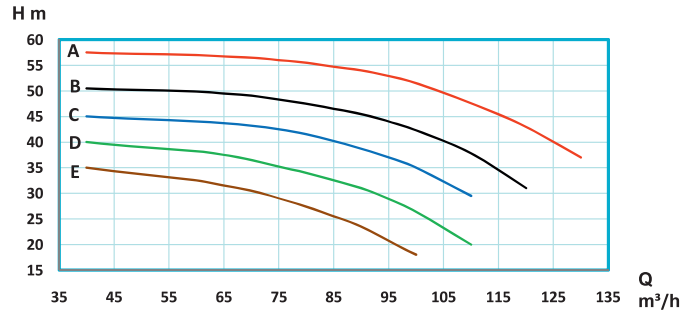

نوع پمپ	قدرت		جریان A	قطر بروانه D (mm)	قطر فلانچ پمپ (mm)		آبدهی (m ³ /h)	40	60	70	80	90	100	120	130	140	150	160	170	180	190
	KW	HP			رانس	مکش		4.6	4.4	4.3	4.2	4	3.8	3.3	3	2.6	2.2	*	*	*	*
ETA4 100-160 E	2.2	3	5	150/110	100	125	H (m)	4.6	4.4	4.3	4.2	4	3.8	3.3	3	2.6	2.2	*	*	*	*
ETA4 100-160 D	2.2	3	5	160/120	100	125		5.5	5.3	5.1	5	4.8	4.6	4.2	3.9	3.6	3.2	2.8	2.4	*	*
ETA4 100-160 C	3	4	7	169/130	100	125		6.4	6.2	6.1	6	5.8	5.6	5.2	4.9	4.6	4.3	3.9	3.5	*	*
ETA4 100-160 B	3	4	7	169/150	100	125		7.4	7.2	7.1	7	6.8	6.6	6.2	5.9	5.6	5.3	4.9	4.5	4	3.5
ETA4 100-160 A	4	5.5	9	169	100	125		8.3	8.1	8	7.8	7.7	7.5	7.1	6.8	6.5	6.2	5.8	5.4	4.9	4.4

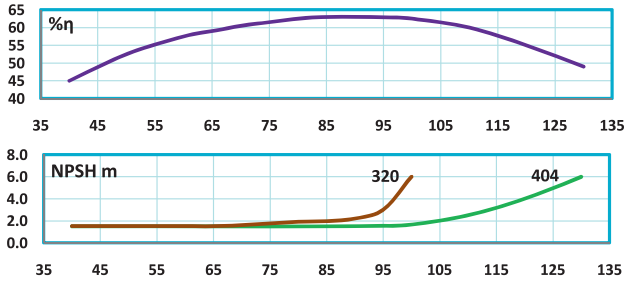
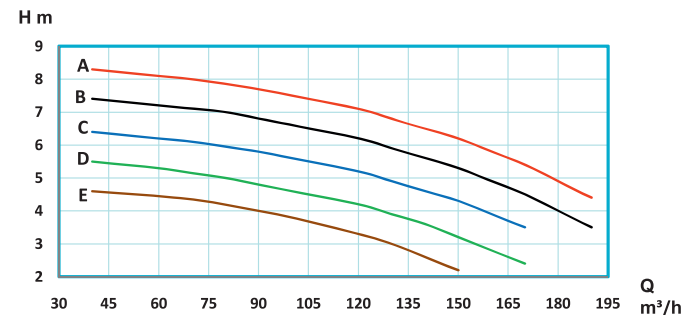
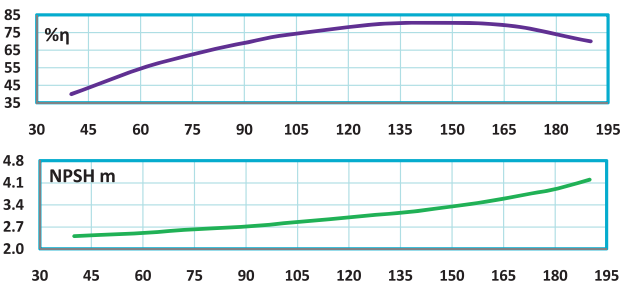

نوع پمپ	قدرت		جریان A	قطر بروانه D (mm)	قطر فلانچ پمپ (mm)		آبدهی (m ³ /h)	40	60	70	80	90	100	120	130	140	150	160	170	180	190	
	KW	HP			رانس	مکش		9.4	9.1	8.8	8.5	8.1	7.7	6.5	5.7	4.7	3.3	*	*	*	*	
ETA4 100-200 E	4	5.5	9	170	100	125	H (m)	9.4	9.1	8.8	8.5	8.1	7.7	6.5	5.7	4.7	3.3	*	*	*	*	
ETA4 100-200 D	5.5	7.5	12	180	100	125		10.5	10.2	10	9.8	9.5	9.2	8.2	7.6	6.8	5.6	*	*	*	*	
ETA4 100-200 C	5.5	7.5	12	190	100	125		11.8	11.6	11.4	11.2	11	10.7	10	9.4	8.6	7.5	6.3	*	*	*	*
ETA4 100-200 B	7.5	10	16	200	100	125		13.3	13.1	13	12.8	12.6	12.4	11.8	11.3	10.6	9.8	8.7	7.5	*	*	
ETA4 100-200 A	7.5	10	16	209	100	125		14.8	14.7	14.7	14.6	14.5	14.3	13.8	13.3	12.7	11.9	11.1	10.2	9.1	7.6	

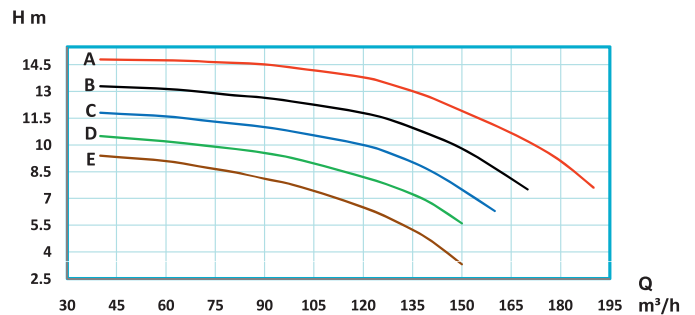
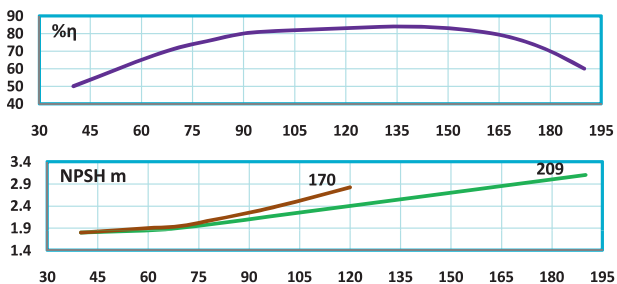

ETA 4 1450 r.p.m

تیپ پمپ	قدرت		حریان A	قطر پروانه D (mm)	قطر فلانچ پمپ (mm)		آبدهی (m ³ /h)	40	60	70	80	90	100	120	130	140	150	160	170	180	190		
	KW	HP			رانش	مکش		16	15.5	15	14.4	13.6	12.7	10.6	9.5	*	*	*	*	*	*	*	*
ETA4 100-250 E	5.5	7.5	12	220	100	125	H (m)	16	15.5	15	14.4	13.6	12.7	10.6	9.5	*	*	*	*	*	*	*	
ETA4 100-250 D	7.5	10	16	230	100	125		17.6	17	16.6	16.1	15.5	14.8	13	12	10.7	*	*	*	*	*	*	*
ETA4 100-250 C	11	15	22	240	100	125		19.4	18.7	18.4	18	17.5	16.9	15.4	14.4	13.2	11.7	10.2	*	*	*	*	*
ETA4 100-250 B	11	15	22	250	100	125		21	20.4	20.1	19.7	19.2	18.7	17.4	16.6	15.5	14.4	13	11.4	9.5	*	*	*
ETA4 100-250 A	11	15	22	259	100	125		22.5	22.1	21.8	21.43	21	20.5	19.2	18.5	17.6	16.7	15.5	14.1	12.6	10.8	*	*

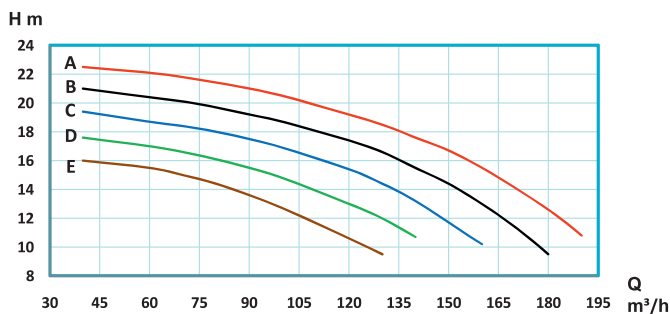
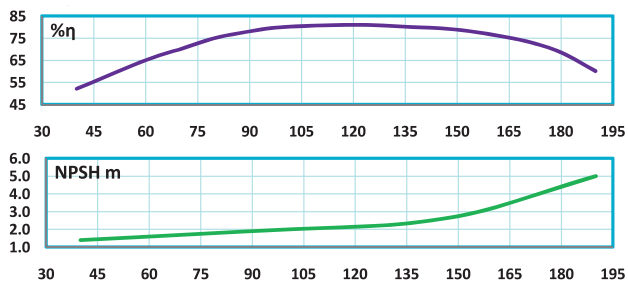

تیپ پمپ	قدرت		حریان A	قطر پروانه D (mm)	قطر فلانچ پمپ (mm)		آبدهی (m ³ /h)	40	60	70	80	90	100	120	140	150	160	170	180	190	205	
	KW	HP			رانش	مکش		25.8	25	24.5	24	23.4	22.5	19.8	15.5	13	*	*	*	*	*	*
ETA4 100-315 F	11	15	22	270	100	125	H (m)	25.8	25	24.5	24	23.4	22.5	19.8	15.5	13	*	*	*	*	*	*
ETA4 100-315 E	15	20	29	280	100	125		28	27.2	26.9	26.5	26	25.3	23	19.1	16.8	*	*	*	*	*	*
ETA4 100-315 D	15	20	29	290	100	125		29.5	29	28.7	28.4	27.9	27.2	25	21.7	19.5	17	14	*	*	*	*
ETA4 100-315 C	18.5	25	38	300	100	125		31.5	31.1	30.9	30.5	30.1	29.5	27.7	25.2	23.5	21.6	19	16	*	*	*
ETA4 100-315 B	22	30	43.5	310	100	125		34.5	34.3	34.2	34	33.6	33	31.5	29.3	28	26.5	24.7	22.1	19.6	*	*
ETA4 100-315 A	22	30	43.5	319	100	125	36.2	36	35.9	35.7	35.5	35.1	34	32.1	31	29.7	28	26	23.5	19.5	*	*

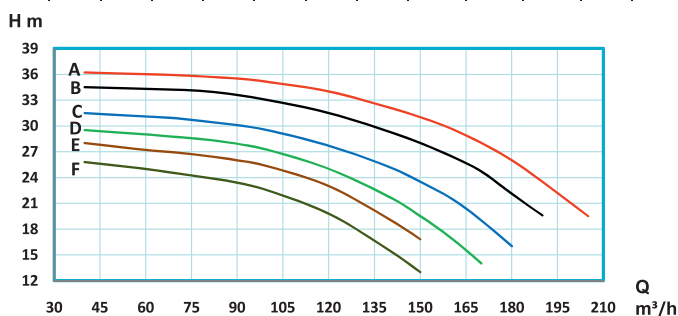
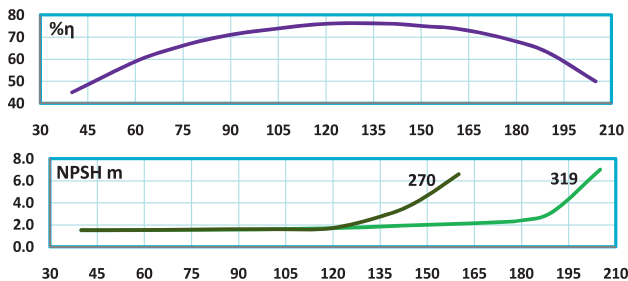

تیپ پمپ	قدرت		حریان A	قطر پروانه D (mm)	قطر فلانچ پمپ (mm)		آبدهی (m ³ /h)	40	60	70	80	90	100	120	150	160	170	180	190	200	210
	KW	HP			رانش	مکش		36	35.9	35.6	35	34.1	33	29.9	22	19	*	*	*	*	*
ETA4 100-400 F	15	20	29	320	100	125	H (m)	36	35.9	35.6	35	34.1	33	29.9	22	19	*	*	*	*	*
ETA4 100-400 E	22	30	43.5	340	100	125		41	40.5	40	39.4	38.5	37.6	35	28.8	26	*	*	*	*	*
ETA4 100-400 D	30	41	58	360	100	125		46	45.6	45.4	45	44.4	43.5	41	36.5	34.5	*	*	*	*	*
ETA4 100-400 C	37	50	71	380	100	125		51	50.5	50.1	49.7	49.1	48.5	46.9	43	41.2	39	36.6	33.5	30	*
ETA4 100-400 B	37	50	71	400	100	125		56.5	56.2	56.1	55.9	55.5	55	53.5	50.4	49	47	44.9	42	39	36
ETA4 100-400 A	45	60	87	404	100	125	57.5	57.3	57.2	57	56.6	56.1	54.8	52	50.5	48.7	46.5	43.8	41	38	

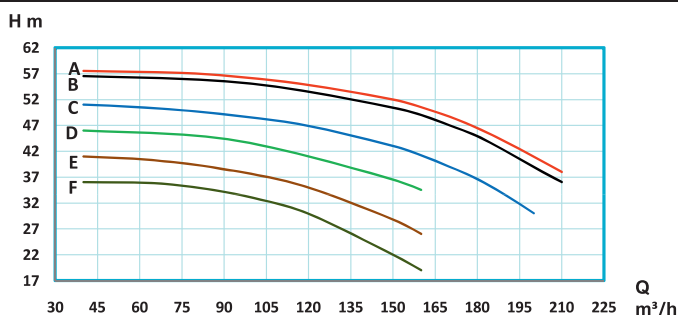
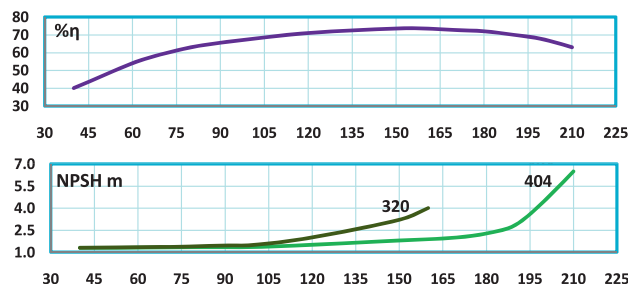

ETA 2900 r.p.m

تیپ پمپ	قدرت		حریان	قطر پروانه		قطر فلنج پمپ (mm)		آبدهی (m ³ /h)	50	80	100	110	120	135	150	160	180	200	220	240	245	250
	KW	HP		A	D (mm)	رانس	مکش		H (m)													
ETA 80-200 E	18.5	25	36	170	80	100	H (m)	35.7	34.2	32.8	31.7	30.3	28	25	23	18.2	*	*	*	*	*	
ETA 80-200 D	22	30	42.5	180	80	100		41.5	40	38.6	37.5	36.3	34.2	31.8	29.7	24.8	19.8	*	*	*	*	*
ETA 80-200 C	30	41	57	190	80	100		46.9	45.6	44.5	43.8	42.7	41	38.5	36.5	31.9	27	22	*	*	*	*
ETA 80-200 B	30	41	57	200	80	100		52.5	51	49.8	49.1	48.1	46.5	44.6	43	39.1	35	29.9	24	22	*	*
ETA 80-200 A	37	50	69	209	80	100		58	56.8	55.8	55.1	54.1	52.6	50.8	49.4	46	42.4	37.7	31.5	29.9	*	*

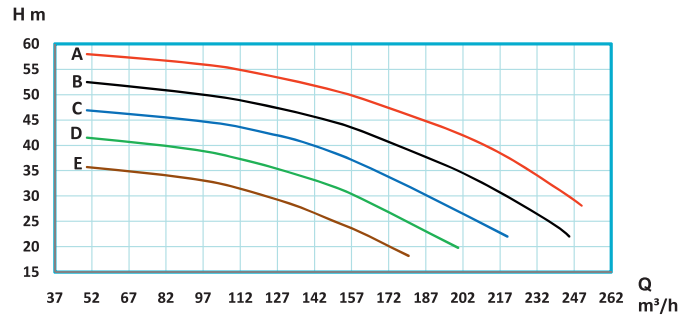
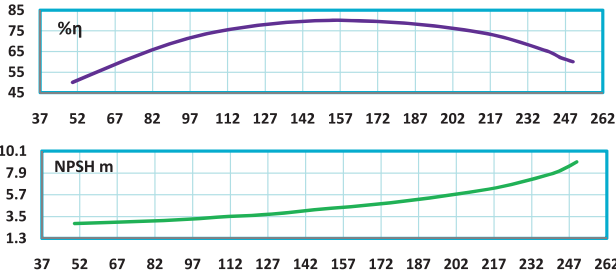

تیپ پمپ	قدرت		حریان	قطر پروانه		قطر فلنج پمپ (mm)		آبدهی (m ³ /h)	50	80	100	110	120	135	150	160	180	200	220	240	245	250	
	KW	HP		A	D (mm)	رانس	مکش		H (m)														
ETA 80-250 F	30	41	57	210	80	100	H (m)	57	56	54.5	53.7	52.4	50.5	48	46	41	33	*	*	*	*		
ETA 80-250 E	37	50	69	220	80	100		64.2	63.4	62	61	60	58	55.7	54	49.3	43.5	36	*	*	*	*	
ETA 80-250 D	45	60	83	230	80	100		71	70	68.5	67.7	66.8	65	63	61.2	57.4	52	46	39	*	*	*	
ETA 80-250 C	55	75	104	240	80	100		78	77	76.1	75.5	75	73.6	71.8	70.2	66.4	61.9	56	79	47	45	*	*
ETA 80-250 B	75	100	140	250	80	100		85	84	83.1	82.5	82	80.8	79.1	77.9	74.8	71.2	66.5	60	58	56	*	*
ETA 80-250 A	75	100	140	259	80	100		92	91	90	89.5	88.8	87.5	86	85	82.3	79.3	75.4	69.9	68.1	66.3	*	*

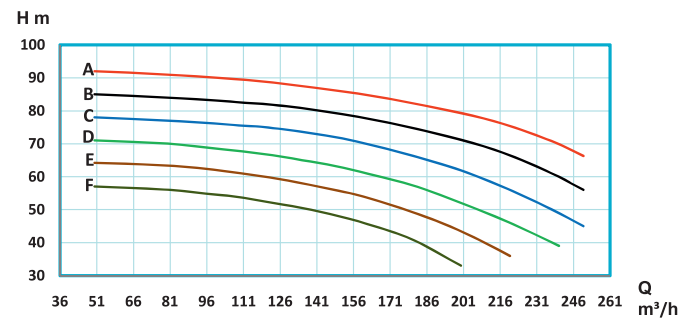
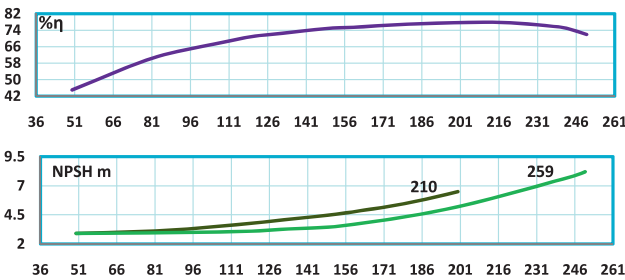

تیپ پمپ	قدرت		حریان	قطر پروانه		قطر فلنج پمپ (mm)		آبدهی (m ³ /h)	100	125	150	175	200	225	250	260	275	300	325	340	350	380
	KW	HP		A	D (mm)	رانس	مکش		H (m)													
ETA 100-160 E	15	20	30	150/110	100	125	H (m)	18.7	18	17.1	16.1	15.1	14	12.9	12.4	11.6	*	*	*	*	*	
ETA 100-160 D	18.5	25	36	160/120	100	125		21.5	20.9	20.1	19.3	18.4	17.5	16.3	15.8	14.9	13	*	*	*	*	*
ETA 100-160 C	22	30	42.5	169/130	100	125		25	24.5	23.9	23	22.1	21.2	20	19.5	18.6	16.8	15	14	*	*	*
ETA 100-160 B	30	41	57	169/150	100	125		29	28.5	27.8	27.1	26.3	25.3	24	23.5	22.5	20.7	18.8	17.5	16.5	*	*
ETA 100-160 A	30	41	57	169	100	125		32.5	32	31.5	30.8	30	29	27.9	27.4	26.6	25	23.2	22.1	21.3	18.9	*

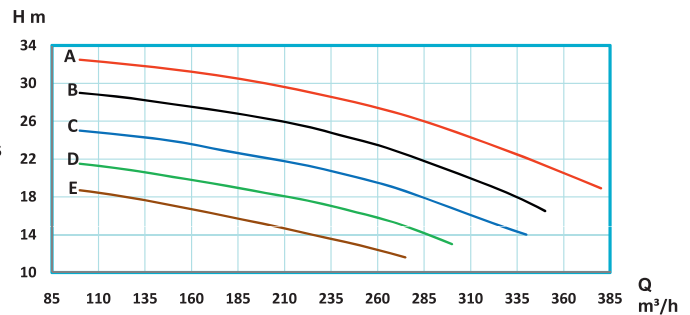
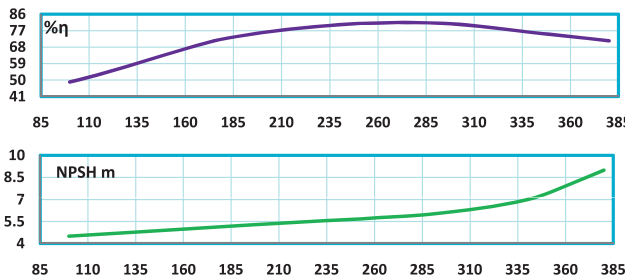

ETA 2900 r.p.m

تیپ پمپ	قدرت		جریان A	قطر پروانه D (mm)	قطر فلانچ پمپ (mm)		آبدهی (m ³ /h)	50	100	125	150	175	200	225	250	270	275	300	325	350	380
	KW	HP			رانس	مکش		50	100	125	150	175	200	225	250	270	275	300	325	350	380
ETA 100-200 E	30	41	57	170	100	125	H (m)	37	36	35	33.9	32.4	30.2	27.5	24	21	20	*	*	*	*
ETA 100-200 D	37	50	69	180	100	125		42.5	42	41.2	40.2	38.7	36.5	33.7	30.9	27.9	27	22.6	*	*	*
ETA 100-200 C	45	60	83	190	100	125		47.1	46.6	46.1	45.3	44.1	42.3	40	37.4	34.9	34.2	30	25	*	*
ETA 100-200 B	55	75	104	200	100	125		53.5	52.9	52.3	51.5	50.6	49	47	44.8	42.8	42.2	38.6	34.5	29.1	*
ETA 100-200 A	55	75	104	209	100	125		59.5	59	58.7	58.2	57.4	56.2	54.8	52.8	50.9	50.3	47	42.8	37.6	30.9

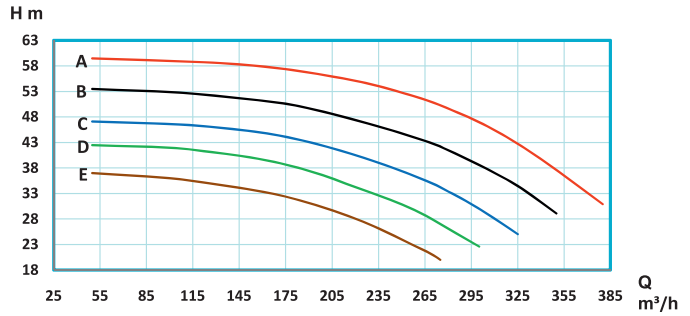
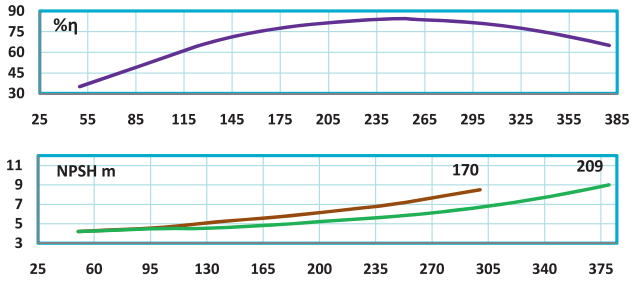

تیپ پمپ	قدرت		جریان A	قطر پروانه D (mm)	قطر فلانچ پمپ (mm)		آبدهی (m ³ /h)	50	100	125	150	175	200	225	250	260	275	300	325	350	390
	KW	HP			رانس	مکش		50	100	125	150	175	200	225	250	260	275	300	325	350	390
ETA 100-250 E	45	60	83	220	100	125	H (m)	64	63	61.8	59.5	56	51.5	45.3	38.3	35.3	30	*	*	*	*
ETA 100-250 D	55	75	104	230	100	125		70.8	69	68	66	63	59.5	54.3	48.3	45.5	41	33.1	*	*	*
ETA 100-250 C	75	100	140	240	100	125		77	75.1	74	72.9	70.3	67	62.7	57.8	55.6	51.7	45	37	*	*
ETA 100-250 B	75	100	140	250	100	125		84	82.1	81	79.8	77.9	75.6	72	67	65	61.3	55.1	47.6	40	*
ETA 100-250 A	90	122	166	259	100	125		90	89	88	86.9	85.1	82.9	80	76.3	74.5	71.9	66.8	60	53	40

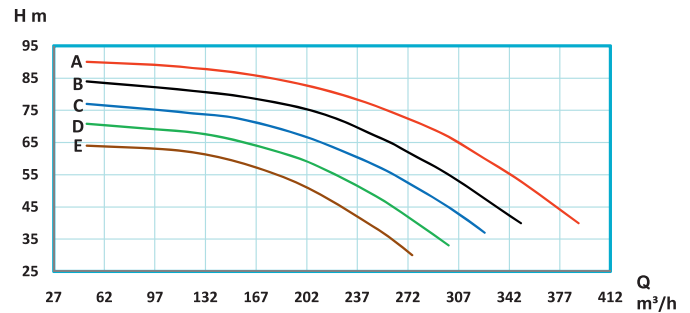
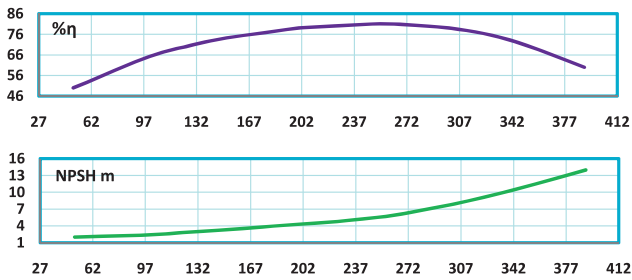

تیپ پمپ	قدرت		جریان A	قطر پروانه D (mm)	قطر فلانچ پمپ (mm)		آبدهی (m ³ /h)	100	150	175	200	225	250	275	300	325	350	400	425	450	490
	KW	HP			رانس	مکش		100	150	175	200	225	250	275	300	325	350	400	425	450	490
ETA 125-200 E	37	50	69	170	125	150	H (m)	36.5	36	35.5	34.7	33.5	31.8	29.6	27.2	24	*	*	*	*	*
ETA 125-200 D	45	60	83	180	125	150		41	40.5	40	39.5	38.8	37.8	36	33.5	31	28.5	*	*	*	*
ETA 125-200 C	55	75	104	190	125	150		45.6	45.1	45	44.6	44	43.2	42	40	37.5	35	30	*	*	*
ETA 125-200 B	75	100	140	200	125	150		50.4	50.1	50	49.8	49.4	48.8	48	46.5	44.6	42.6	38.3	35.7	32.45	*
ETA 125-200 A	75	100	140	209	125	150		55.3	55	54.7	54.5	54	53.5	53	52.1	50.8	49	45.3	42.8	40.3	36

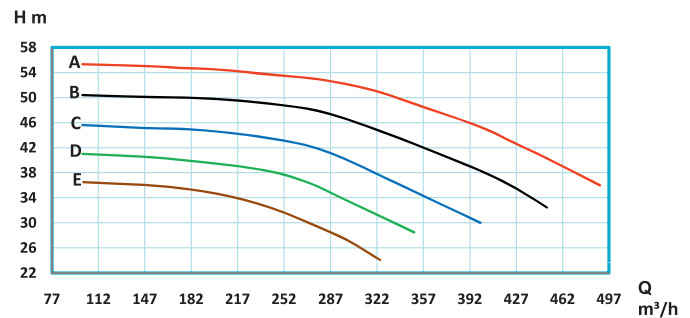
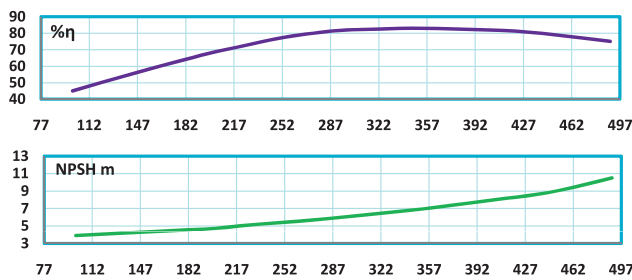

80-100
125-200 & 125-250
150-200 & 150-250 & 150-315 & 150-400

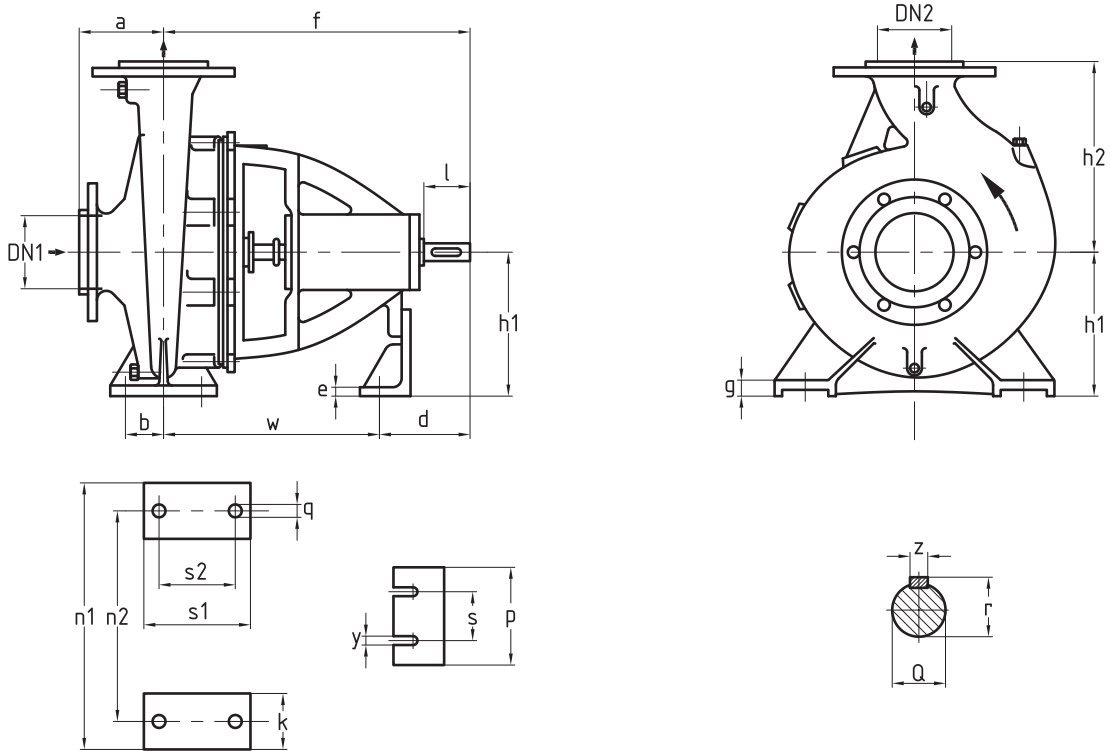

TYPE	mm																							
	DN1	DN2	a	f	h1	h2	l	w	b	d	e	g	n1	n2	q	s1	s2	k	p	s	y	Q	z	r
ETA 80-160				360	180	225	50	265	47.5	95		17	320	250	14	125	95	65				24	8	26.9
ETA 80-200						250					8		345	280										
ETA 80-250	100	80	125	470	200	280	80	340	80	130			400	315					160	110	14	32	10	35.3
ETA 80-315					250	315						18			18	160	120	80						
ETA 80-400				530	280	355	110	370	60	160	12		435	355								42	12	45.1
ETA 100-160	125	100	125	470	200	280	80	340	60	130	8	18	360	280	18	160	120	80	160	110	14	32	10	35.3
ETA 100-200																								
ETA 100-250				470	225	280	80	340	60	130	8	18	400	315	18	160	120	80				32	10	35.3
ETA 100-315	125	100	140		250	315													160	110	14			
ETA 100-400				530	280	355	110	370	75	160	12	20	500	400	23	200	150	100				42	12	45.1
ETA 125-200						315			80		12													
ETA 125-250	150	125	140	470	250		80	340	60	130	17	18	400	315	18	160	120	80	160	110	14	32	10	35.3
ETA 150-200				470			80	340		130			550	450										
ETA 150-250					280	400							500	400								32	10	35.3
ETA 150-315	200	150	160						75		12	20			23	200	150	100	160	110	14			
ETA 150-400				530			110	370		160			550	450								42	12	45.1
					315	450																		